

# EMERGING TECHNOLOGIES FOR HIGH PERFORMANCE COST-EFFECTIVE GLAZING AND WINDOW UPGRADES

RAN-RAM  
Level 1  
Energy Audit  
Information  
Series



# What are we trying to do today?



## Window Retrofit Technology Backgrounder

- Quick History of How and Why Window and Glass Technology Evolves
- New Rapidly Emerging High Impact Glass Technologies and Solutions
  - Alpen Product Solutions

## How to Use the Information Effectively

- Analyzing Options for Window Retrofit Approaches
- Important Considerations in Evaluating Retrofit Options

# Glass Technology Develops Slowly

---



**R Zero Windows**



**R1 Windows 100 A.D.**

# Glass Technology Development Over Time

---

## Patent Double Pane Glass Unit

Thomas Stetson 1865

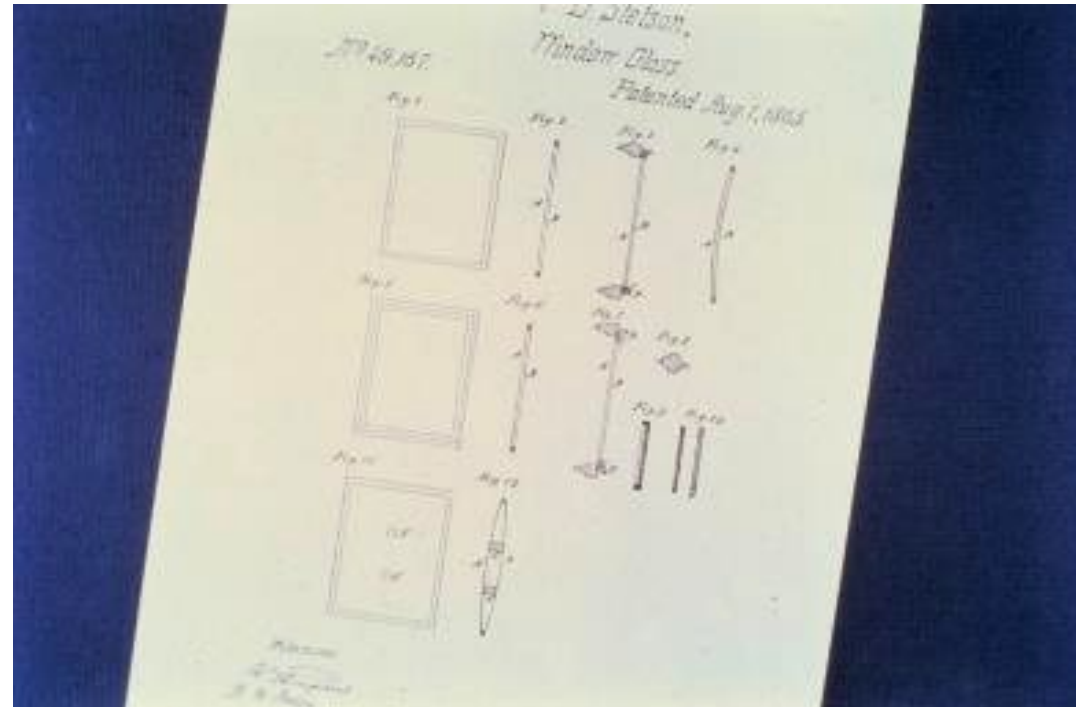

**R2 Windows**

# Fenestration Technology Development is Inevitable

---



## Rule Number One:

New Impactful Technology in Fenestration Market  
Rarely Develops When It Is Imagined

## Rule Number Two:

If the Technology Solves Problems and Adds Value,  
at the Right Time, It Develops Really Fast!

Really, Really Fast! Often With a Triggering Event.

# The Four Critical Industry Innovations Dominated Last 50 Years+

---

1. Invention of the Float Glass Process
2. Transition from Single to Dual Pane Insulated Glass Units
3. Commercialization of Low-e Coatings on Glass
4. Rise of Vinyl Windows

# Some Critical Innovations in the Last 50 Years - Float Process

---



Publicly  
Announced  
1959

# Some Critical Innovations in the Last 50 Years - Float Process

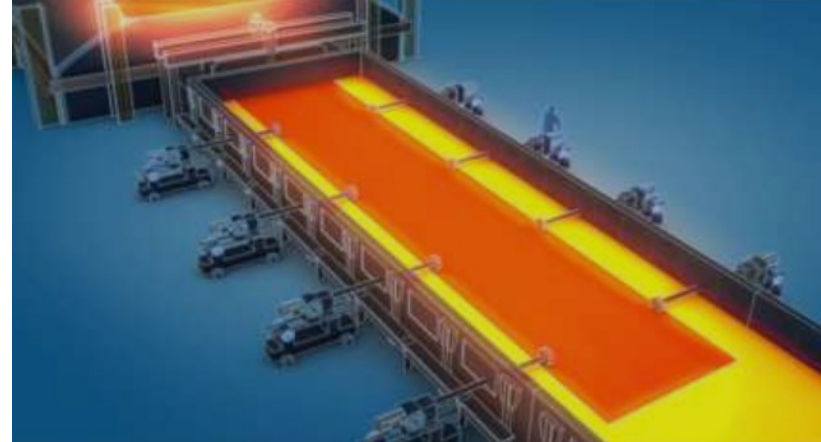
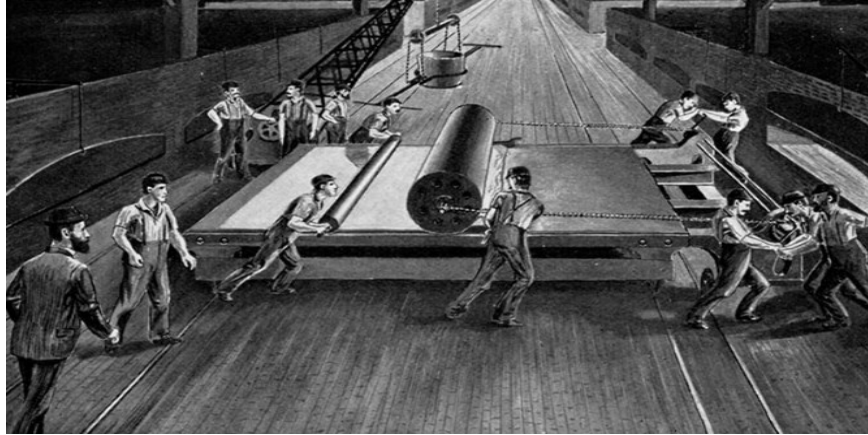

Comparison of Maximum Flat Glass Sheet Sizes (Feet)

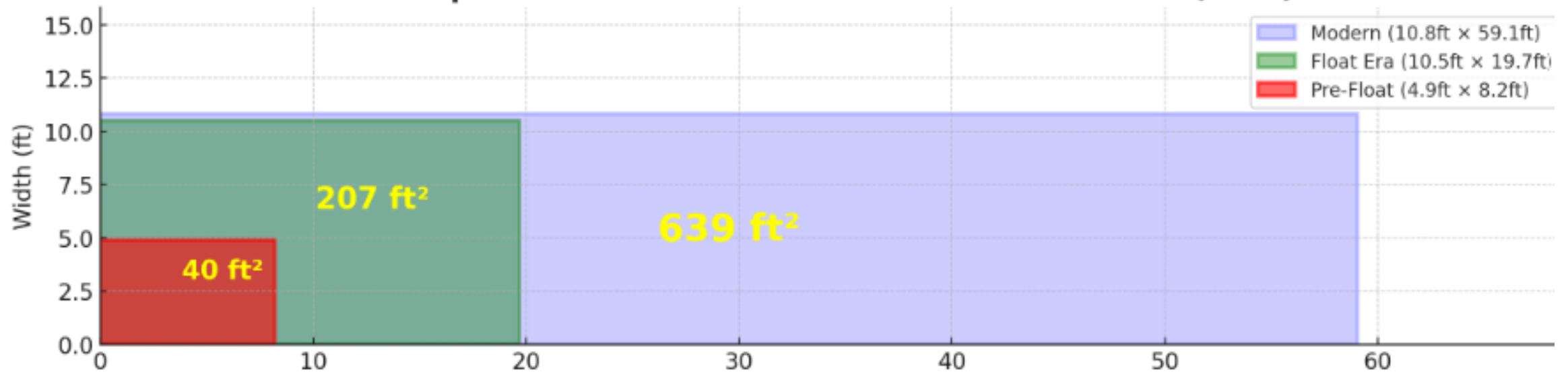

DRAMATIC DROP IN COST, INCREASE AVAILABILITY AND SIZE

# Some Critical Innovations in the Last 50 Years - Float Process

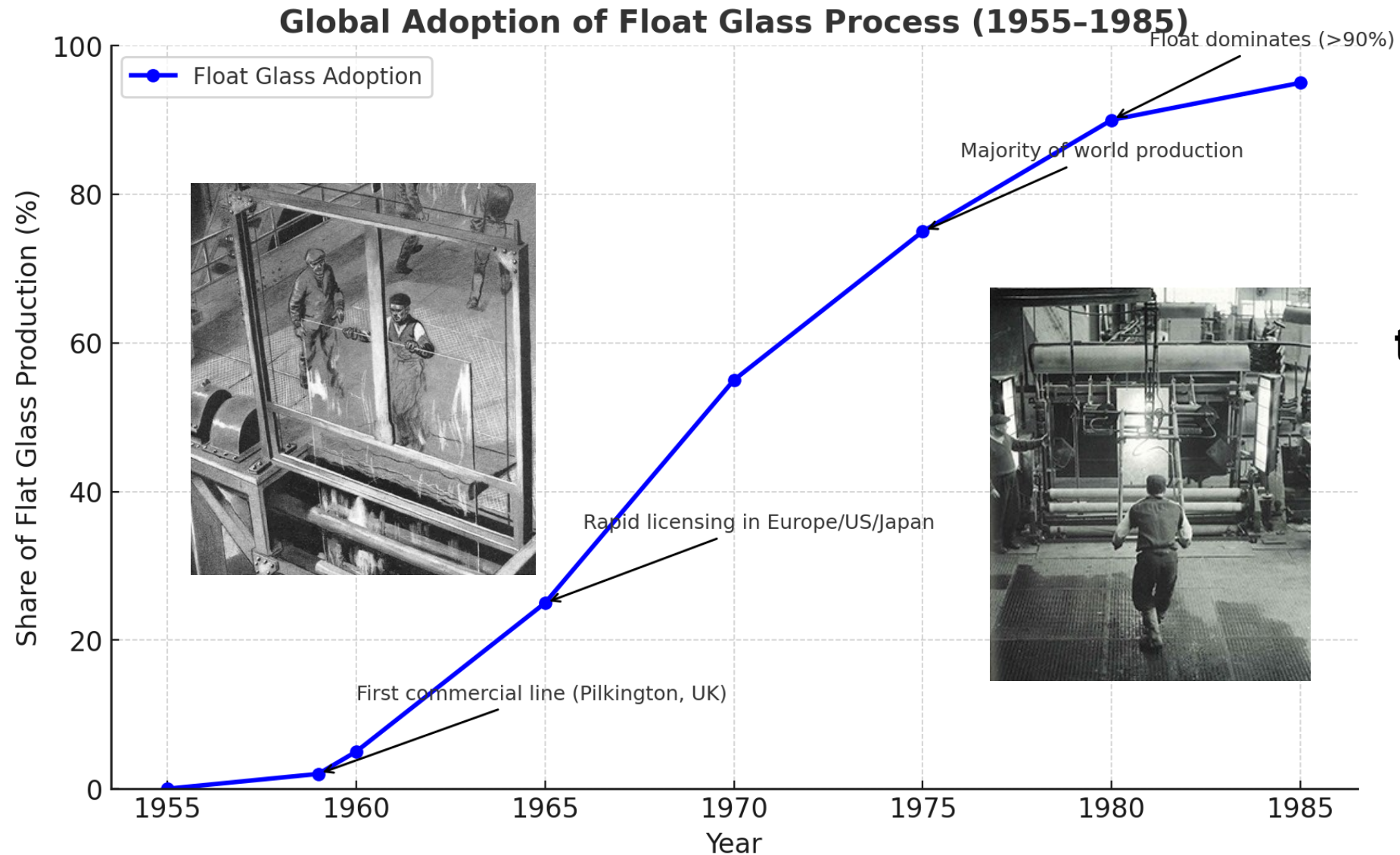

**Transforms  
the Industry  
Overnight**

# Some Critical Innovations in the Last 50 Years

## Float Glass Triggers Other Rapid Advancements

### DOUBLE PANE WINDOWS

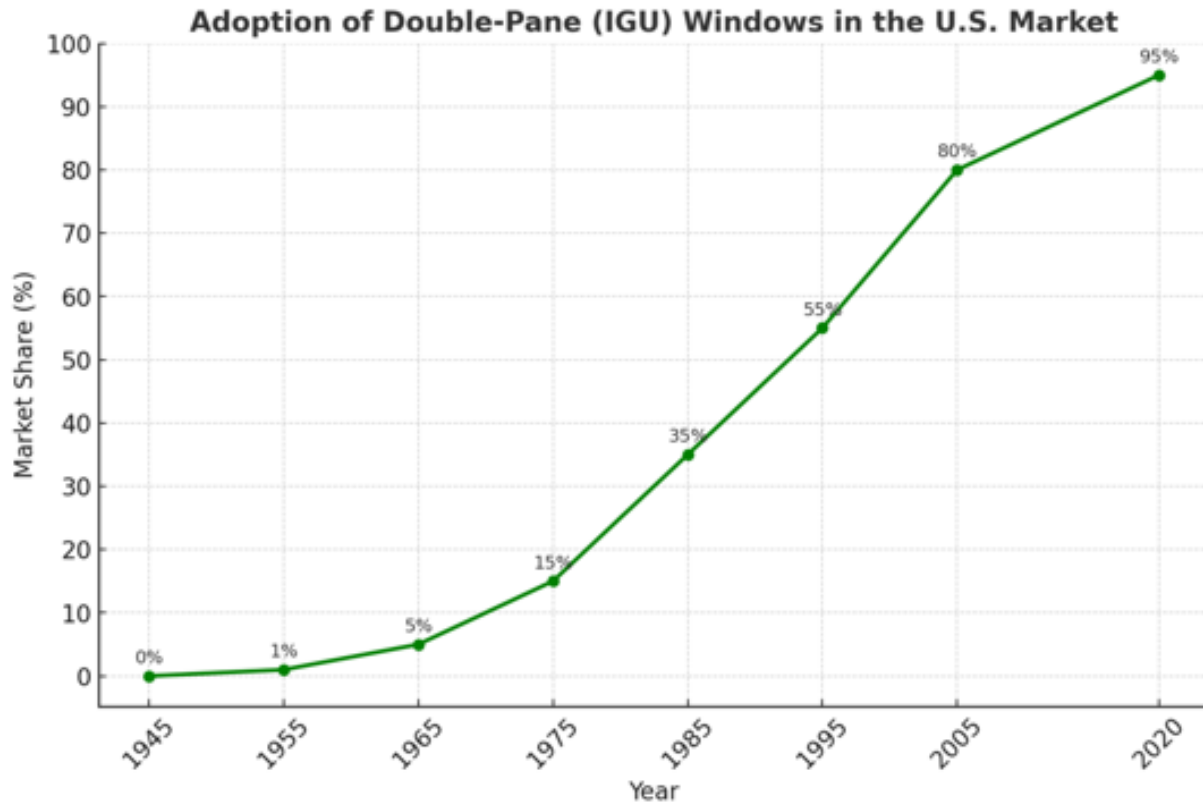

### LOW-E GLASS

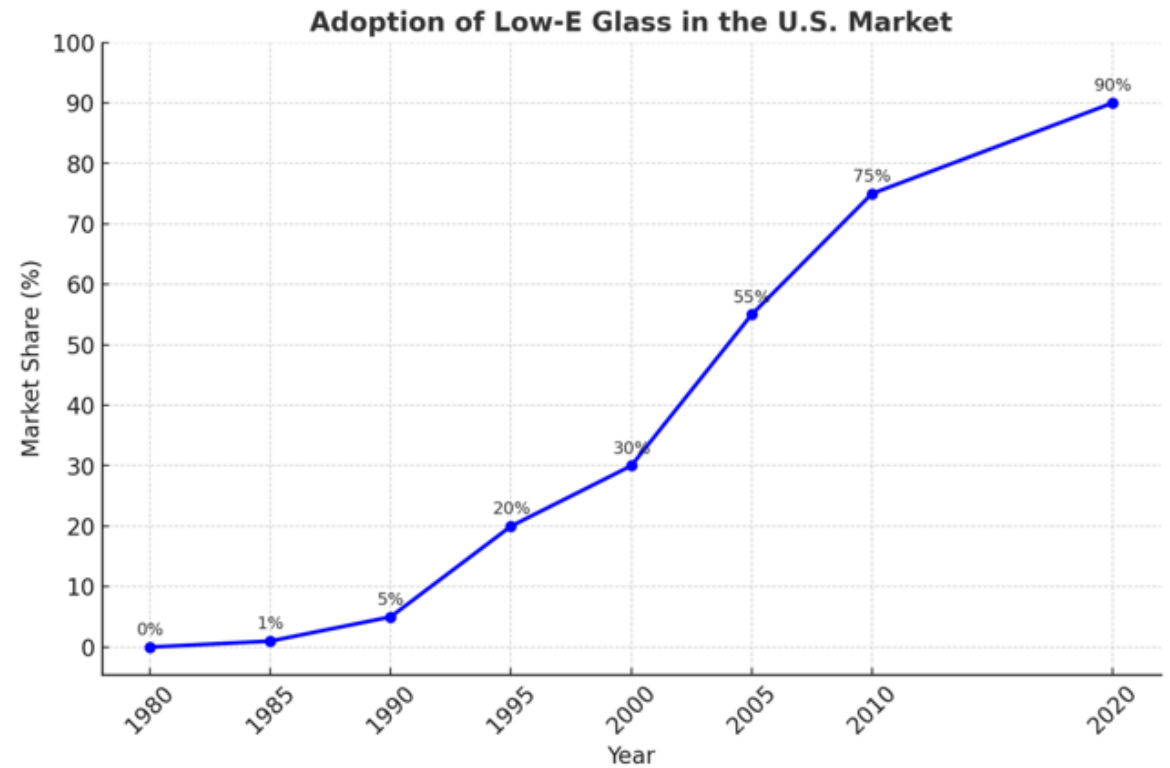

# Some Critical Innovations in the Last 50 Years- Vinyl Windows

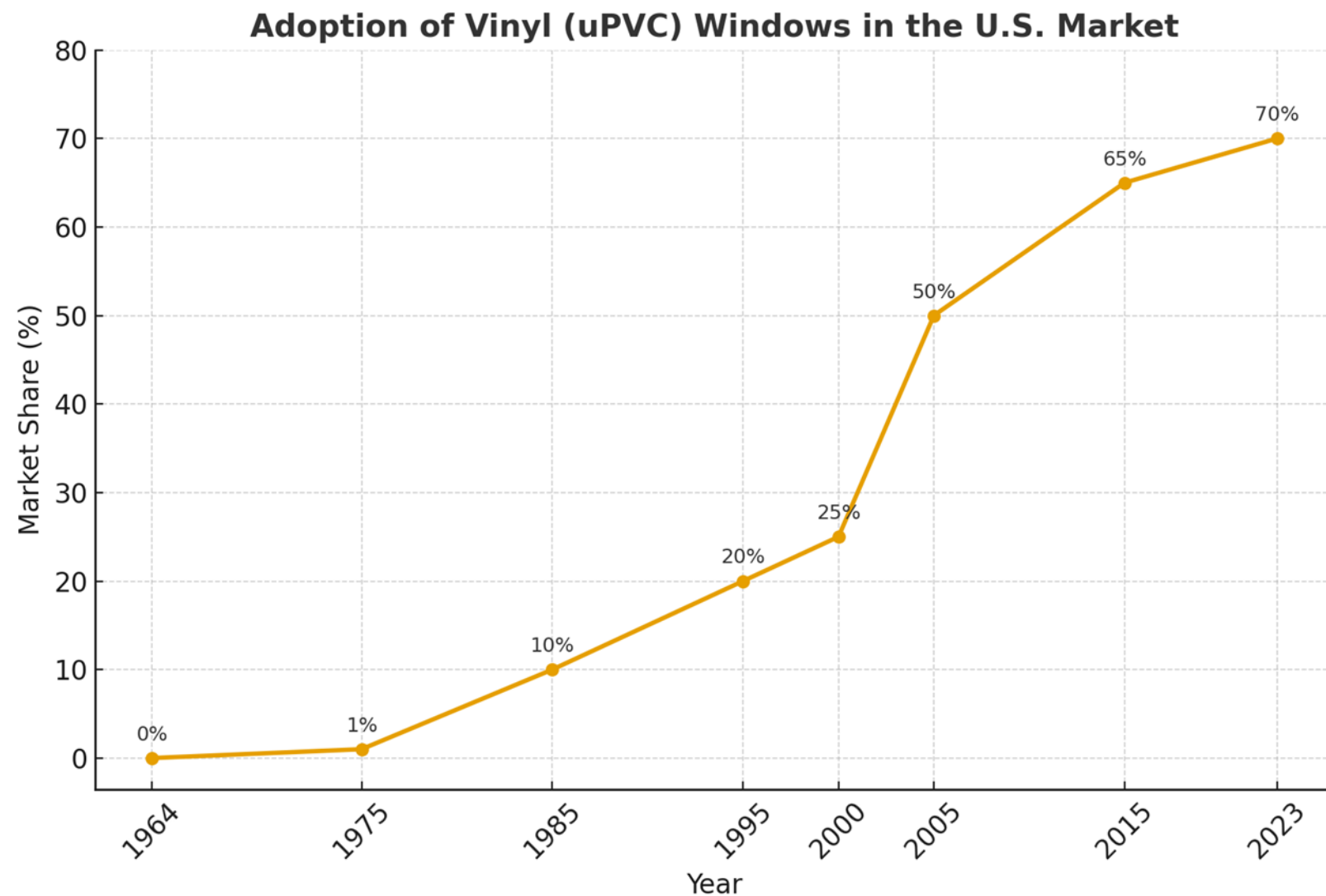

**DOMINATE MARKET  
SHARE IN UNITED STATES**

# S-Curve of Innovation In the U.S. Window Industry

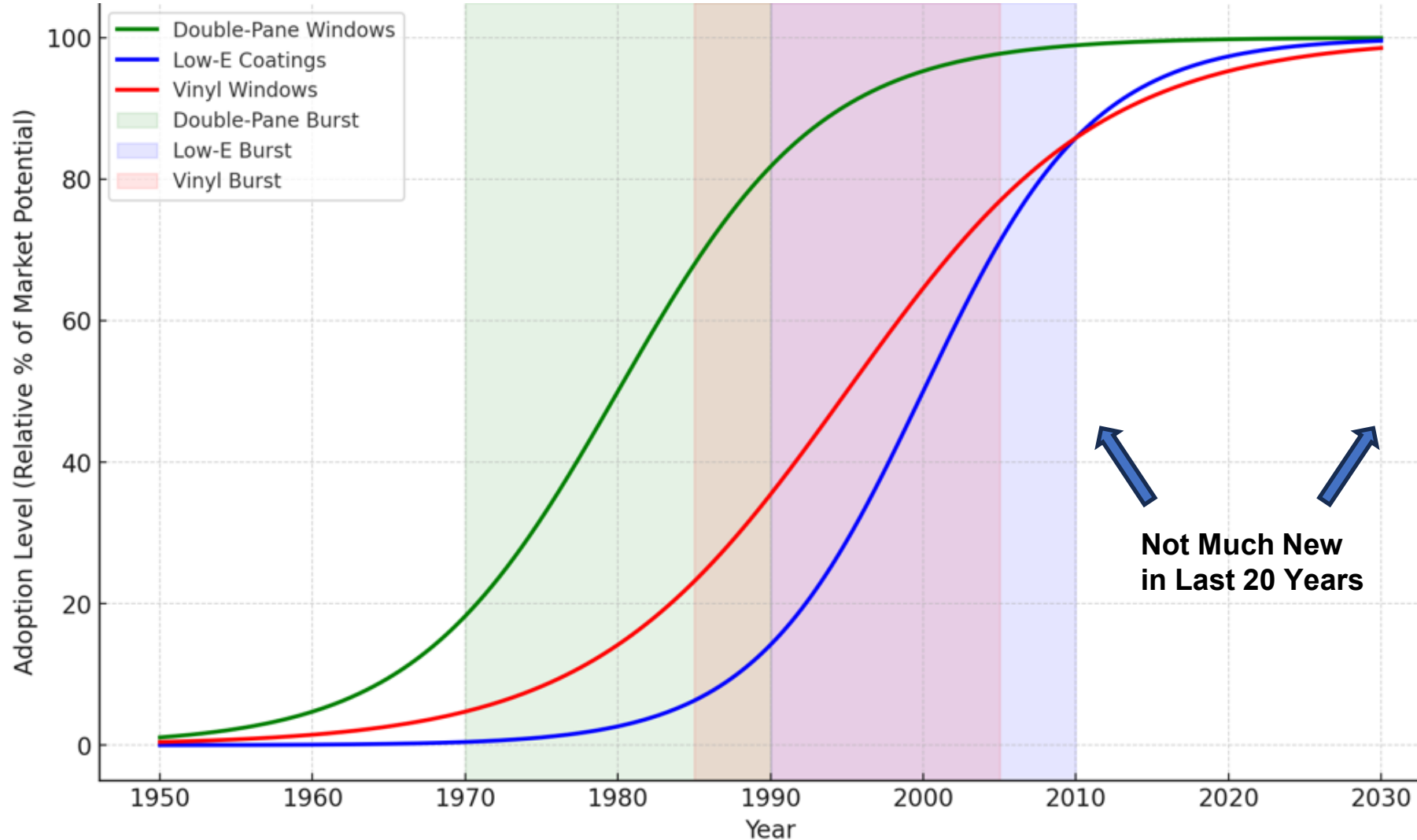

1. **Technological Breakthroughs**
2. **Economic & Regulatory Shocks Accelerate Adoption**
3. **S-Curve of Innovation**
4. **Clustered Ecosystem Development**
5. **Market Saturation & Risk Aversion**

# Overall US Window “Styles” Haven’t Changed Much



US Window Design  
1700s



US Window Design  
Today

# The Prototypical “Energy Efficient” Window Sold in the United States

---

## 1995 – R3

Anatomy of an Efficient Window

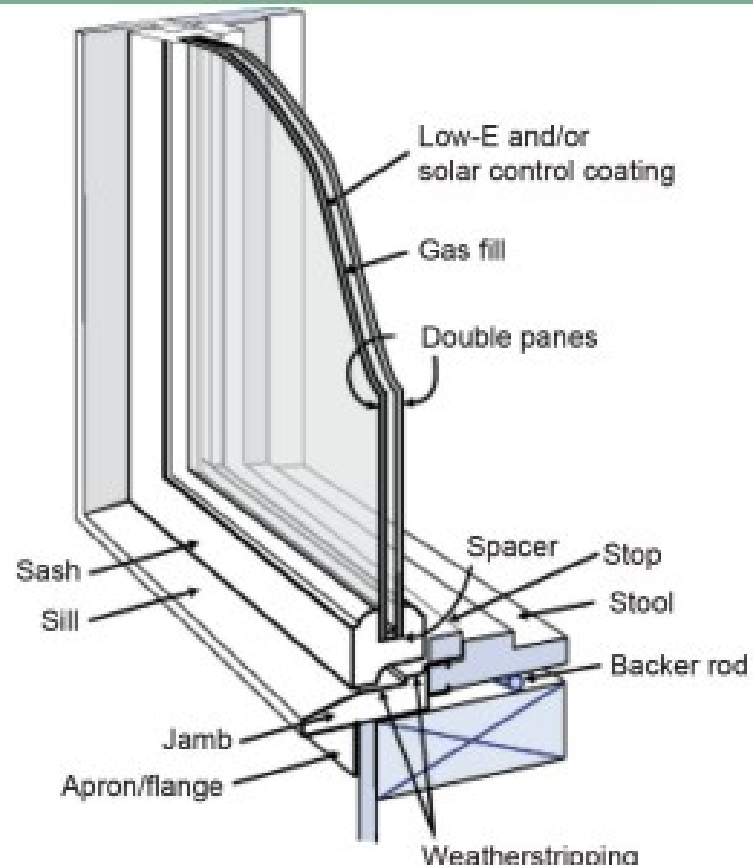

# The Prototypical “Energy Efficient” Window Sold in the United States

## 2024 R3.5

Anatomy of an Efficient Window

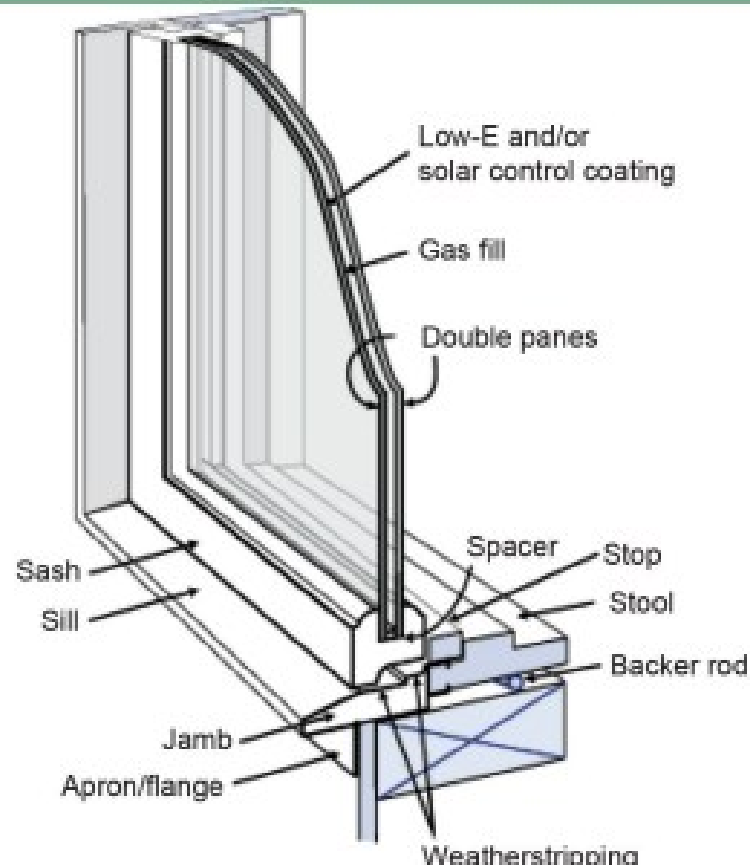

**YOU:** CUTE HISTORY LESSON. TICK TOCK, MAKE IT RELEVANT! SO WHAT?

**ME:** GETTING TO THAT PART.



**WE WILL COME BACK TO “TECHNOLOGY EVOLUTION” IN A MOMENT  
BUT LET’S EXAMINE THE BIGGER ISSUE**

**REMEMBER RULE #2: TECHNOLOGY DEVELOPS FAST IF IT SOLVES  
PROBLEMS, ADDS VALUE AND THE TIME IS RIGHT**

In the non-residential “built environment,” it is well understood **by far** the biggest unsolved challenge to reducing energy intensity is ***poor performing windows*** . . . by a long shot.



ALPEN  
HIGH PERFORMANCE PRODUCTS

8%

Building Surface Area  
Covered by Windows

45%

Building Energy Loss From  
Windows

5.5m Buildings

40b Sq. Ft. Openings

# Facts That May Surprise You:

**50% of existing commercial windows** in the United are considered low performing

- 30% single pane

- 20% lower end non-thermally broken aluminum frames

- Poor thermal performance and leaky

By contrast, the vinyl (and other frame types) residential window replacement market is mature, well organized and ubiquitous

Of all the commercial building in all the country, **less than 10% have ever had windows replaced**

90% of all commercial building stock in 2050 is already in existence today

## Why is this the case?



# THE RETROFIT MARKET IS BROKEN

- 5.5 million commercial buildings
- 5.2 million multi-family residential buildings
- 30% single-pane (4B+ sq. ft.)
- 20% low-performing double-pane (2.5B+ sq. ft.)

Retrofitting windows is a headache to owners, so incumbents focus on new construction

## BUILDING OWNERS

- High cost: \$100-150+/square foot
- Lengthy and disruptive installation
- Uncertain/15+ year payback
- Engineering challenges (weight, etc.)
- Older buildings subject to historic standards

## WINDOW COMPANIES

- Building owners wary of window retrofits
- Retrofit vs. new construction sales process
- Unpredictable installation complications
- Competing investment priorities
- Difficulty matching historic or aesthetic needs

# Traditional Commercial Window Retrofit Solutions

Retrofit Measure	Cost	Tenant Disruption Adder	Payback / ROI Potential	Hidden and Other Issues
<b>Typical Window Replacement</b>	\$\$\$\$	20%	30 – 40 years	Expensive
<b>Historic Window Replacement</b>	\$\$\$\$\$\$	20%	40 + years	Really expensive
<b>Window Weatherization</b> Sealing, Gasket Replacement etc	\$-\$	2%	3 – 10 years	Focuses only on air infiltration
<b>Secondary Windows - Aluminum Frame</b>	\$\$	2% - 10%	8 – 15 years	Pretty good compromise, frame is typically hidden weak spot
<b>Glass Replacement</b>	\$\$	20% - 30%	10 – 30 years	Installation costs; water; Does not address frames
<b>Applied Films</b>	\$	2%	3 – 5 years	No insulation improvement
<b>Exterior Shading Devices</b> Overhangs, rolling shutters etc	\$\$\$	0%	varies	Not always practical on storefront and curtainwall
<b>Interior Shades - low performance</b>	\$-\$	2%	varies	No air infiltration improvement
<b>Interior Shades - high performance</b> Solar shades, insulating shades	\$\$-\$\$\$	2%	3 – 6 years	No air infiltration improvement



# Traditional Commercial Window Retrofit Solutions

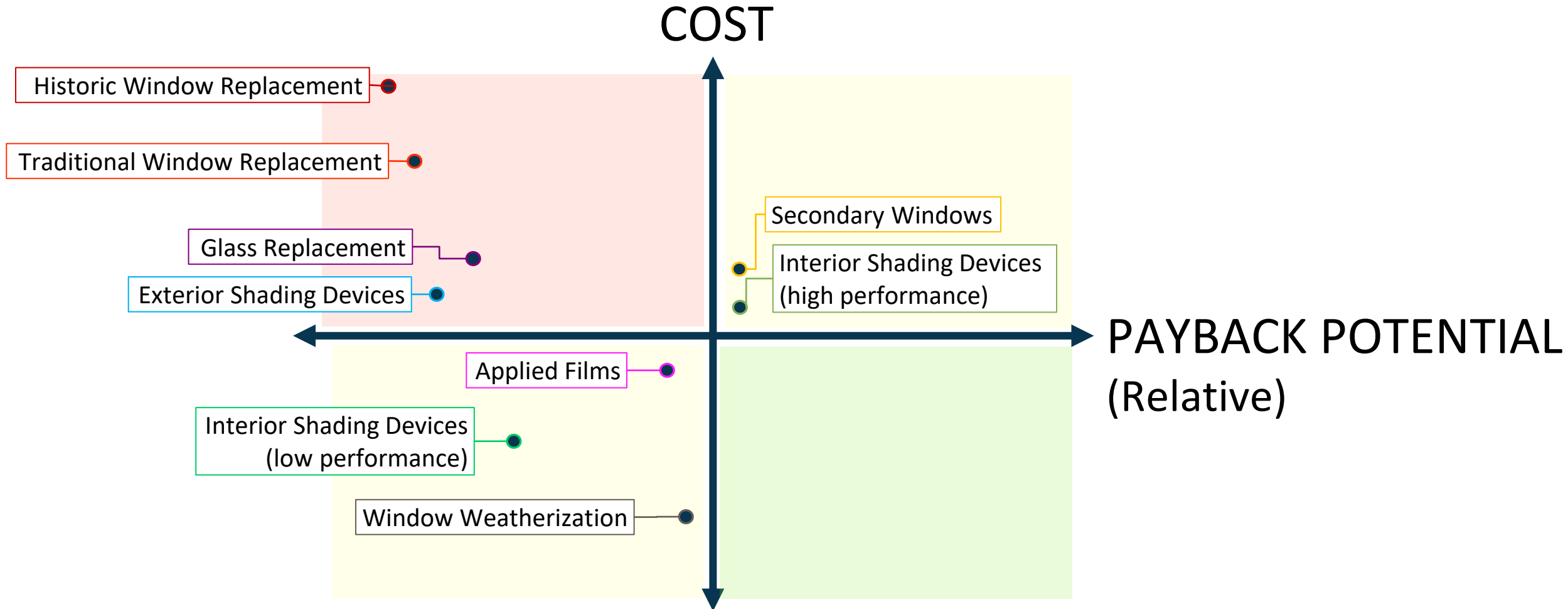

# DEPRESSED YET?



# Who is Alpen?



- ▶ **40+ year industry leader in high performance fenestration products**
- ▶ **First Manufacturer** of suspended coated film products
- ▶ **First R-10 window available** in the U.S. market
- ▶ **First to use “thin glass”** in architectural applications
- ▶ **Components certified to be compliant** with highest standards for testing and certification
- ▶ **DOE “Investing in America” grant awarded in 2024** to expand manufacturing capabilities

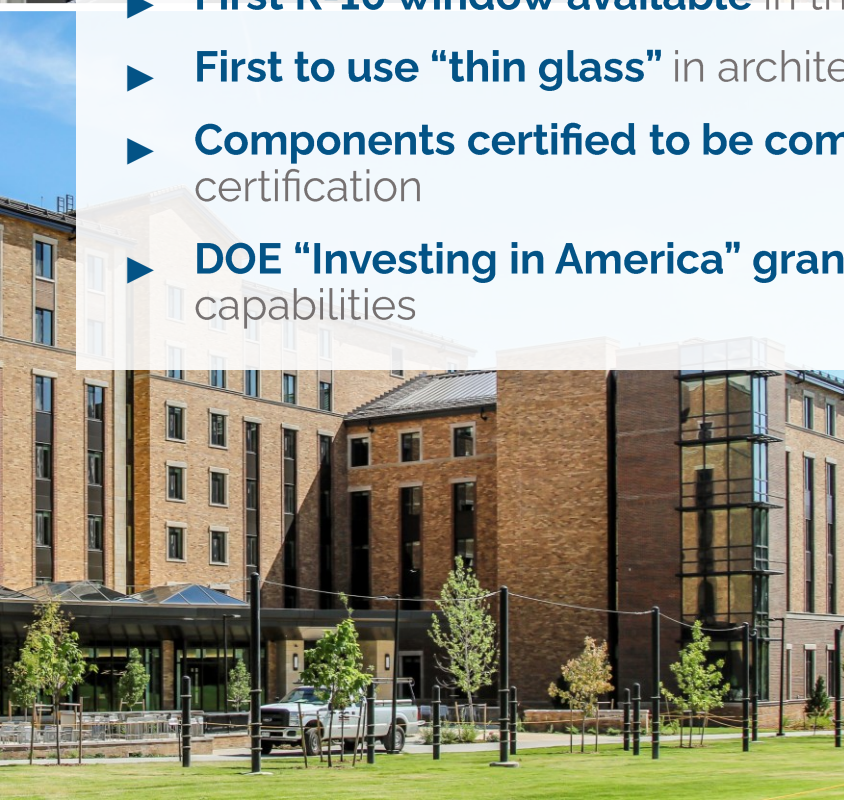

# Alpen Products – “Thin Glass” Centric



## RESIDENTIAL



North American and European style statement windows and doors.

## COMMERCIAL



World-class commercial window and door solutions

## SECONDARY WINDOWS



Quickly and affordably increase the efficiency of aging commercial buildings.

## GLASS



Insulated glass units to help window companies meet rigorous energy standards.

# NOW HOLD THAT THOUGHT



---

## BACK TO HISTORY AND TECHNOLOGY DEVELOPMENT AND TIMING

1. Is there a problem to solve? **COMMERCIAL RETROFIT WINDOW MARKET BROKEN AND DOESN'T WORK**

2. Is there something new happening to drive timing (demand)?

**ENERGY CODES CHANGING QUICKLY**

**REFLECTING RAPIDLY CHANGING PUBLIC SENTIMENT ALONG WITH DEMAND TO DO BETTER**

BUT THERE IS A HIDDEN SECRET ACCELERATOR FEW PEOPLE SEE.

RESOLVE AND URGENCY OF MORE AND MORE STATE AND LOCAL JURISDICTIONS MOVING FAR FASTER  
***AND NO LONGER CONSTRAINED BY WAITING FOR CAUTIOUS BROAD CONSENSUS***

**ALL CRITICALLY IMPACTING TIMING**

# Remember this slide a few minutes ago?

## Some Critical Innovations in the Last 50 Years - Float Process

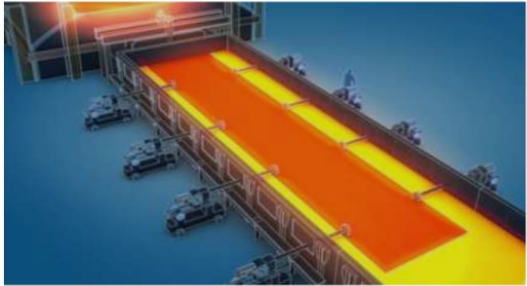
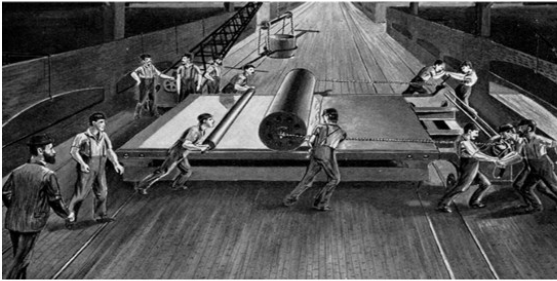

Comparison of Maximum Flat Glass Sheet Sizes (Feet)

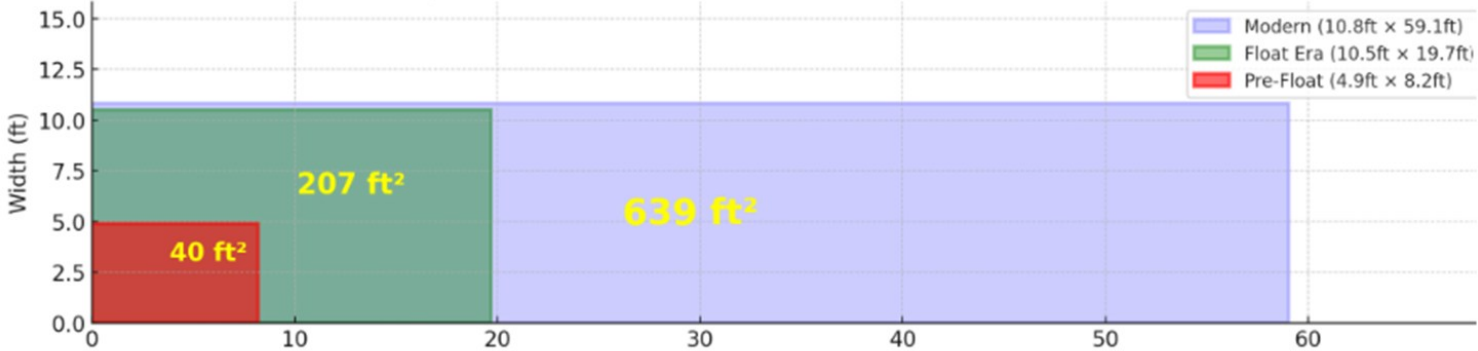

DRAMATIC DROP IN COST, INCREASE AVAILABILITY AND SIZE

# The Most Potentially Transformative Architectural Glass Technology in Last 50 Years

## VERTICAL FUSION TECHNOLOGY --CORNING

Progression of Thin Glass Sheet Sizes (Incremental Areas Colored, in Feet)

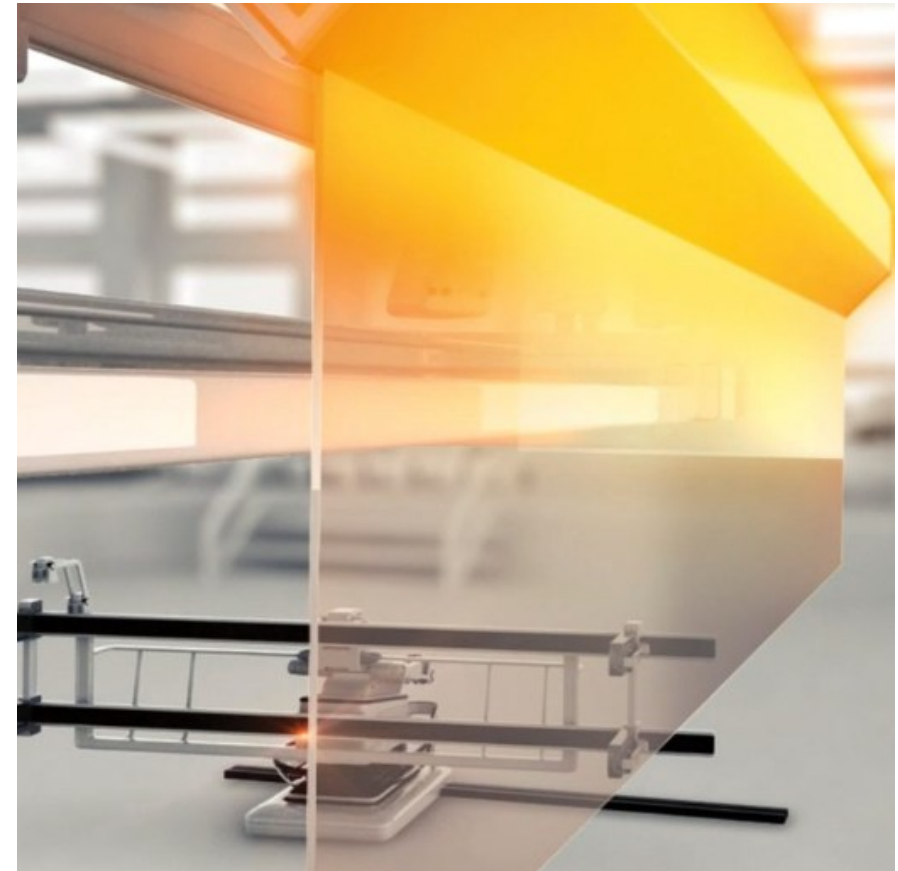
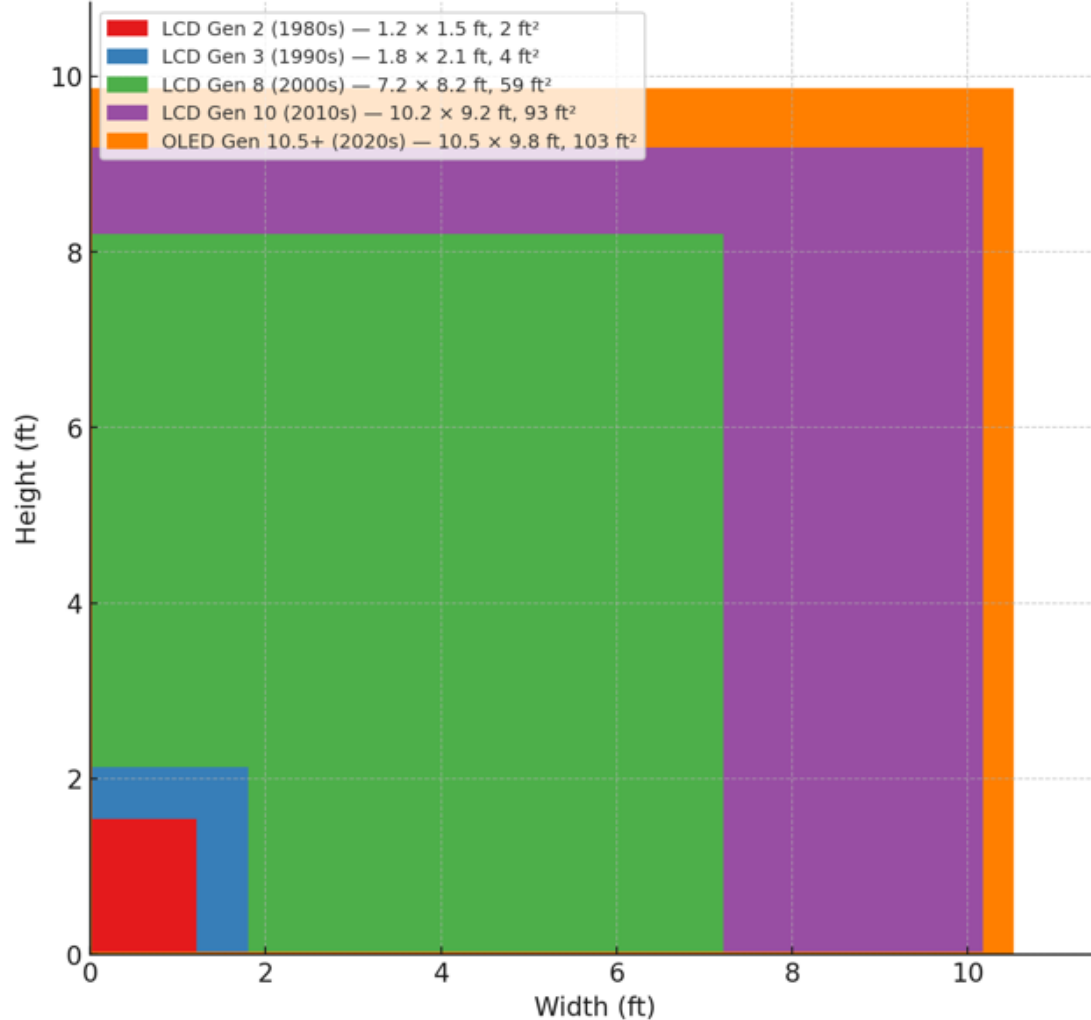

**SUPER THIN GLASS OF OUTSTANDING QUALITY**

# The Most Potentially Transformative Architectural Glass Technology in Last 50 Years

## VERTICAL FUSION TECHNOLOGY --CORNING

1. INVENTED IN **1961** BY CORNING.
2. LIGHTWEIGHT RACECAR WIND SHIELD? NO.
3. IPHONE –FOOTHOLD -**2007** Permitted Fast Commercialization
4. FLATSCREEN TVS –SIZE QUADRUPLED IN **2010s**  
Permitted Big Size and Reduced Cost



Progression of Thin Glass Sheet Sizes (Incremental Areas Colored, in Feet)

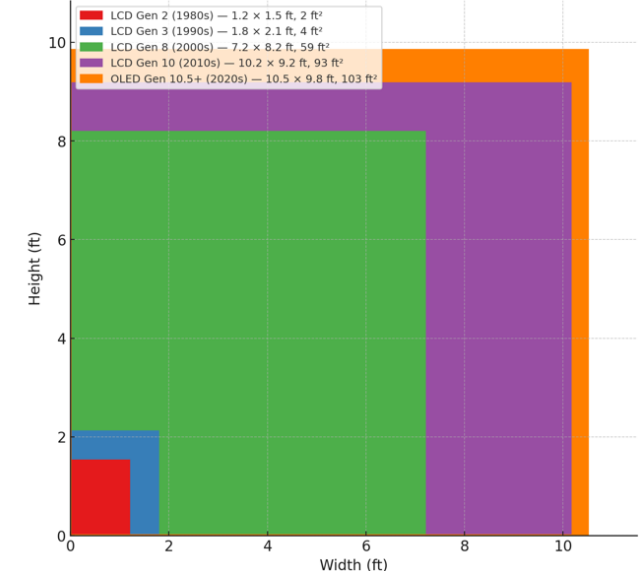

# The Most Potentially Transformative Architectural Glass Technology in Last 50 Years

## VERTICAL FUSION TECHNOLOGY --CORNING

---

1. BIGGER MASTER SHEET SIZE -- **ARCHITECTURAL APPLICATIONS REQUIRED**
2. SIZE OF TV INDUSTRY – ADDED COMPETITORS, PRICE DROPPED --**REALISTIC FOR ARCHITECTUAL**
3. NEEDED AN EARLY ADOPTER - **ALPEN**

2019 TO 2020 – Product evaluation and testing

2020 TO 2022 – Field Use and Learning and Third-Party Evaluation and Validation; Supply Channel

2022 to 2023 – Final Design and Identification of Equipment Automation to Scale (Did Not Exist)

2023 to 2025 – Equipment Purchased and Installed and Product Formally Brought to Market

4. RACE IS ON . . . NOW SIX COMPANIES ENTERING MARKET –  
**REALLY FAST SCALE DRIVEN BY MULTIPLE EQUIPMENT SOLUTIONS AND DE-RISKED**

# Remember “Thin Glass” Centric?

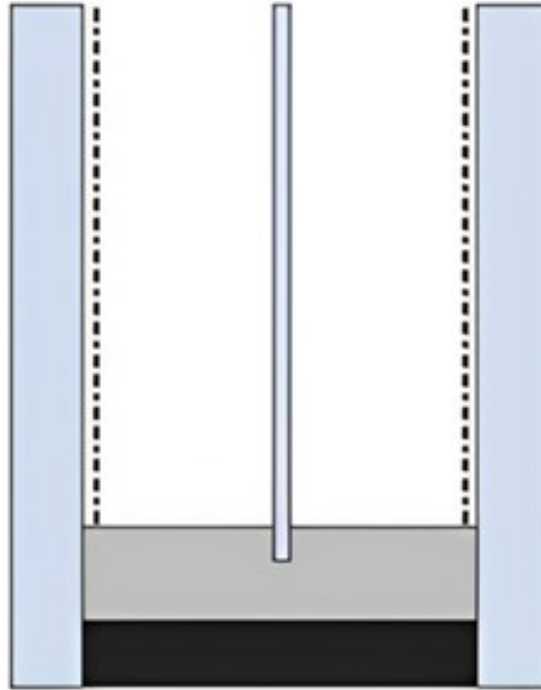
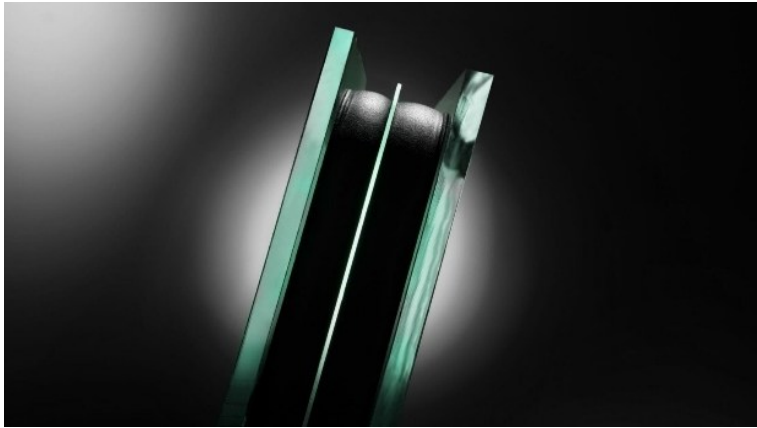

ThinGlass  
Triple  
Pane



**THIN GLASS IS A REMARKABLE PRODUCT WE BELIEVE WILL  
REVOLUTIONIZE THE WINDOW RETROFIT MARKET**



**ALPEN WAS FIRST INNOVATOR TO USE THIN GLASS IN ARCHITECTURAL APPLICATIONS**

**3 MILLION SQUARE FEET IN THE MARKET**

# Two High Speeding Thin Vertical Insulating Glass Lines Installed by Alpen – Only Two in World with Quad Pane Capacity



**PART OF A \$22 MILLION INVESTMENT IN ALPEN TO RAMP GLASS AND WINDOW PRODUCTION AS DEMAND GROWS RAPIDLY FOR HIGHER PERFORMANCE WINDOW PRODUCTS**

# High Performance Thin Glass

Typical Double Pane



Up to R5  
(0.20 u-factor COG)  
1/2" – 1"

ThinGlass Triple Pane



Up to R9  
(0.11 u-factor COG)  
3/4" – 1-1/4"

ThinGlass Quad Pane



Up to R15  
(0.06 u-factor COG)  
1" – 1-1/2"

# THAT'S ALL NICE BUT WHAT'S IT MEAN?



---

**New solution permitting radically different set of solutions to the built environment**

**New higher performance product solutions that are lightweight and fit as “drop-in” to exact same form factor as existing solutions**

**Solutions that can be installed eventually at scale at a fraction of the price and time as existing failed solutions**

# Window Retrofit Option One: Replace Failed Glass with a Thin Glass Triple IGU



Figure 11. Thin triple-pane IGUs glazed into existing double-pane vinyl frames (Pasco, WA).

## Laboratory and field validation of the performance benefits and costs of thin triple-pane windows in residential buildings

Patricia Gunderson , Edward Louie  & Katherine Cort

## When to do it and why

- Good non-leaky existing frame; bad glass
- Existing glass pocket at least .75" wide
- Typically, not more than two stories or can be installed from inside
- Can be lowest cost option to upgrade windows and as inexpensive as 15% to 25% of a replacement window option
- Fast and non-disruptive
- Upgrade a poor or fair window to a high performance window
- Main challenge is it will typically requires a glazing contractor (mark ups?)

<https://doi.org/10.1080/23744731.2024.2357529>

# THIN GLASS TRIPLE IG UNIT

- **SAME EXISTING FORM (WAS DUAL PANE)**
  - **NOW TRIPLE PANE**
  - **.24 POUNDS/FT<sup>2</sup>**
  - **PERFORMANCE 2X TO 2.5X**

**INCREMENTAL COST FT/2 =**



# Window Retrofit Option Two: Window Replacement

---



## When to do it and why

- Other low-cost solutions don't work and existing windows must be replaced
- Choice becomes one of price and performance
- Lowest cost options typically vinyl but not always appropriate
- Huge range of prices but typically start at \$750-\$1000
- Some installed sales options exist and some require the buyer to hire an installer
- Will have potential substantial occupant disruption

# Alpen Window Systems

## Zenith Series



## Tyrol Series



## Aspekt+ Series



Fiberglass American Style Windows  
Outswing Casement, Awning, Fixed, Hung, Sliding

uPVC European Style Windows  
Inswing Tilt-Turn, Hopper, Fixed

uPVC American Style Windows  
Casement, Awning, Fixed

Certified by:  

Certified by:   

Certified by:  

# Window Retrofit Option Three: High Performance Secondary Windows

## When to do it and why



- Bad glass/window with 1" of unobstructed vertical space to inside of existing windows, usually offers the best overall solution
- Similar in cost to thin triple glass replacement and effective
- Can be installed with minimal supervision and training by handy layman
- Almost zero occupant disruption
- Major air infiltration improvement
- Limits with currently obstructed areas to inside of window or opening requiring operability (until 4Q25)

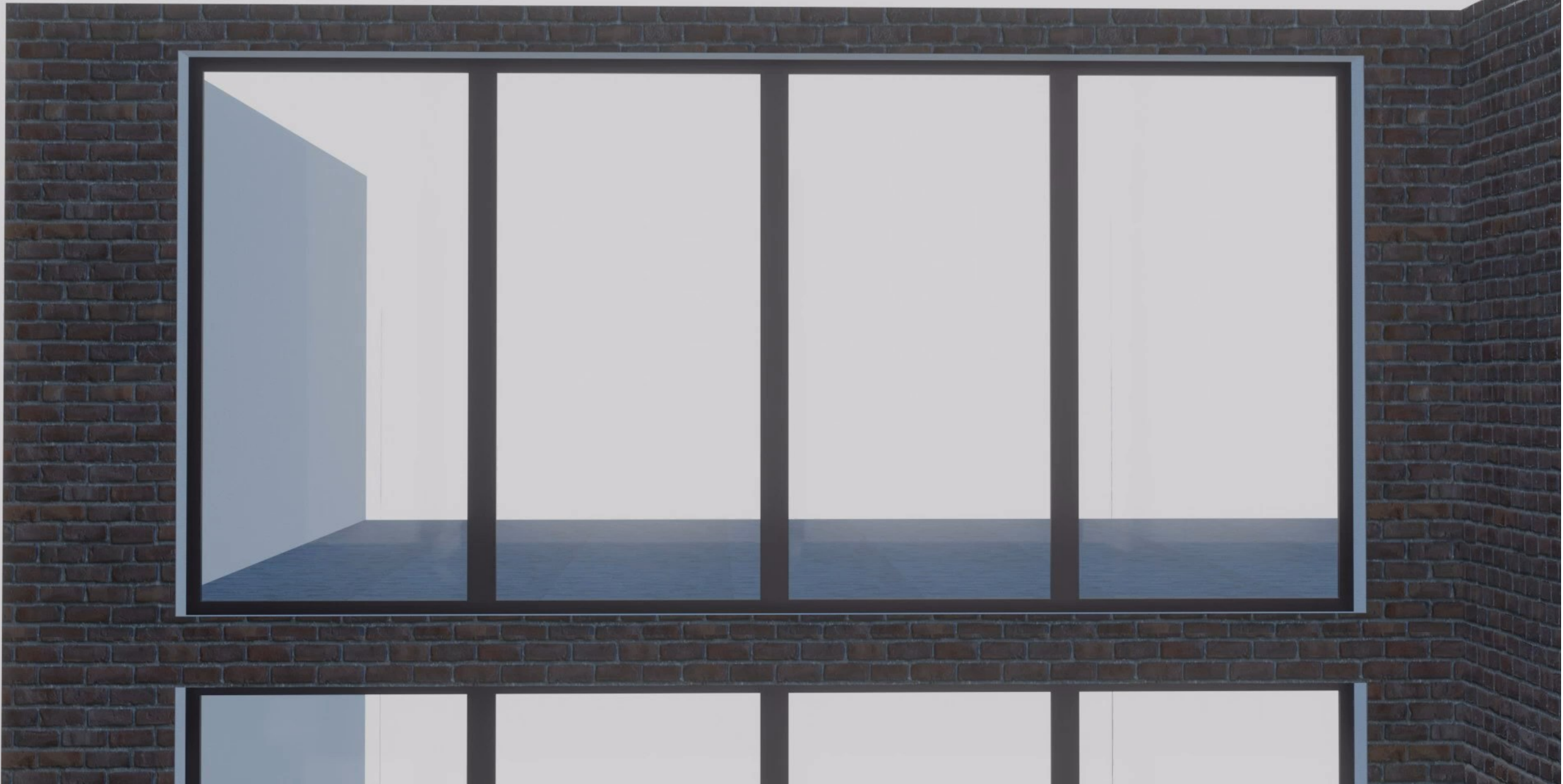

# Virtually Invisible—From R1 up to R6



# Alpen's WinSert Product

*Patented lightweight high performance secondary window*

- *Installed to interior of primary windows*
- *Can be installed in single window*
- *Can be installed in mulled combinations*
- *Unlimited colors*
- *Multiple attachment options*
- *Fixed or operable*
- *Customizable*



Inserted into Single Window or Combination Windows Conditions

# WinSert™ Secondary Windows

## EXISTING WINDOW

Non-Thermally-Broken  
Aluminum Single Pane



U-Value: 1.12

SHGC: 0.72

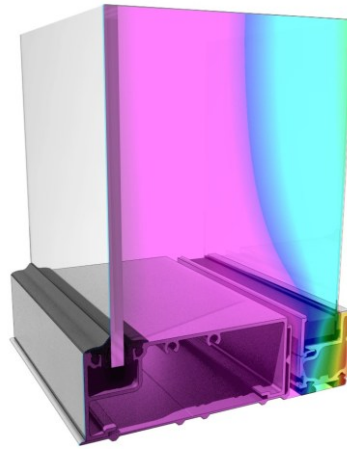

## EXISTING WINDOW + WinSert Lite

U-Value: 0.47

Improved by 2.4x!

SHGC: 0.41

Reduced 43%!

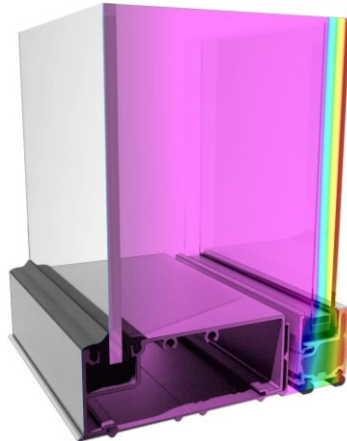

## EXISTING WINDOW + WinSert Plus

U-Value: 0.19

Improved by nearly 6x!

SHGC: 0.30

Reduced 58%!

# Best-in-Class Lightweight Retrofit Solution



Under 1 lb per square foot



Beautiful aesthetics, clean lines, and color match.

# **WINSERT SECONDARY WINDOW SOLUTION**

- **CAN IMPROVE EXISTING WINDOW TO TRIPLE EQUIVALENT**
  - **8% TO 12% COST FULL WINDOW REPLACEMENT**
  - **OVERINSULATES POOR FRAME/SEALS LEAKS**
  - **FAST/NO OCCUPANT DISRUPTION/MOVE**

**ALL ENABLED BY THIN GLASS UNIQUELY**

# WinSert Case Studies

## 915 Broadway, Vancouver WA



- <https://files.thinkalpen.com/hubfs/Case%20Studies/Broadway%20St%20WinSert%20Case%20Study.pdf>
- <https://www.youtube.com/watch?v=rhrmYCMXwc0>

## VA Administration Building, Houston TX



- <https://files.thinkalpen.com/hubfs/Case%20Studies/VA%20Regional%20Office%20WinSert%20Case%20Study.pdf>

# WinSert Case Studies

## Crane Aerospace, Lynnwood WA



- <https://files.thinkalpen.com/hubfs/Case%20Studies/Crane%20Aerospace%20WinSert%20Case%20Study.pdf>

## GSA Green Proving Ground, Denver, CO



- [https://www.gsa.gov/system/files/Applied\\_Research/NREL-79112-Lightweight%20Secondary%20Windows.pdf](https://www.gsa.gov/system/files/Applied_Research/NREL-79112-Lightweight%20Secondary%20Windows.pdf)

# Other Window Retrofit Options: The More Traditional Stuff

## When to do it and why



- Window treatments, solar control films and caulking guns are often the other option
- Huge range of options and can still be quite expensive
- Little insulating improvement and little air infiltration improvement or frame performance improvement
- Similar in cost to glass replacement and secondary windows

# Final Thoughts for Modelers



- Find credible data for “whole window” performance

- Windows

- Use NFRC certified data (<https://nfrf.org/certified-product-directory>)

Zenith NFRC:

[https://cdn.prod.website-files.com/66a0d107af4de533f9222dba/67a3fe8b845946857089864c\\_zenith%20Full%20frame%20nfrf%20data.pdf](https://cdn.prod.website-files.com/66a0d107af4de533f9222dba/67a3fe8b845946857089864c_zenith%20Full%20frame%20nfrf%20data.pdf)

Tyrol NFRC:

[https://cdn.prod.website-files.com/66a0d107af4de533f9222dba/67a3fe62ee94ef57c45a6c11\\_TYROL%20Full%20Frame%20NFRC%20Data.pdf](https://cdn.prod.website-files.com/66a0d107af4de533f9222dba/67a3fe62ee94ef57c45a6c11_TYROL%20Full%20Frame%20NFRC%20Data.pdf)

- Glass Replacement

- Use LBNL’s Windows 7.6 for accurate glass values and use LBNL’s whole window modeling software for accurate whole window performance (don’t forget frame and edge of glass) (<https://windows.lbl.gov/software-tools>)

- Secondary windows

- Rely on accurate whole window test results on AERC website for credible installed comparative and accurate reliable data for secondary windows –don’t rely on manufacturer's claims (<https://aercenergyrating.org/commercial/commercial-secondary-windows>)

WinSert AERC:

[https://cdn.prod.website-files.com/66a0d107af4de533f9222dba/66ef3c948816db5c38984be8\\_AERC-Data-Table--WinSert-ALL--2022-02--v2.pptx.pdf](https://cdn.prod.website-files.com/66a0d107af4de533f9222dba/66ef3c948816db5c38984be8_AERC-Data-Table--WinSert-ALL--2022-02--v2.pptx.pdf)

# Final Thoughts for Modelers and Owners



- Always consider two other critical inputs in energy models when considering the impact of window upgrades
  - Pre- and post-install air infiltration performance (modeled or measured by blower door test or both)
    - Air infiltration results from upgrades for windows and secondary windows can be enormous
    - Alpen publishes air infiltration results for windows on our website (<https://www.thinkalpen.com>) and for WinSert on the AERC website listings shown on the prior page)
    - Certain types of windows have tighter seals (outswing or inswing is tighter than vertical or horizontal sliding windows)
  - Realistic thermostat set point adjustments (if you are upgrading windows and not changing set points for thermostats in you model) you are dramatically underestimating energy savings as you will be changing behavior for HVAC equipment)
- It is perfectly OK to consider occupant comfort in financial decisions
- Finally, improve the shell before upgrading HVAC (you can pay for much of the shell upgrade if you do) by reducing loads—the most common mistake and often repeated regret
- Where possible, don't settle for cheap; good quality is never as expensive as people think; do your homework



ALPEN

HIGH PERFORMANCE PRODUCTS

# Questions or Follow Up?

ALPEN HIGH PERFORMANCE PRODUCTS

[WWW.THINKALPEN.COM](http://WWW.THINKALPEN.COM)

303-834-3600

---

BRAD BEGIN, CHAIRMAN | [BBEGIN@THINKALPEN.COM](mailto:BBEGIN@THINKALPEN.COM) | 303-883-9001